

Tuning your violin and changing strings

You will need to adjust the tuning of your violin regularly. Your violin strings can be tensioned using both the pegs and the fine tuners on the tailpiece. The violin is tuned to G,D,A,E – G being the thickest string and E the thinnest. The viola is tuned C,G,D,A - C being the thickest and A the thinnest.

You will need a tuning device, there are many on the market including smart phone apps available. Match the tone of each string until the correct pitch is reached.

Occasionally you will need to replace strings. Follow the notes below and diagram A. on the next page.

Remove the old string

1. Remove & replace each string one at a time. Do not remove or slacken all the strings at once, this will cause the bridge to move and possibly the sound post will fall down.
2. Replace the G string first. Turn the peg towards you to loosen the string & pull the string to unravel it from the peg.
3. Unhitch the ball end from the tailpiece and remove string

Fit the new string

1. With the G string removed pull the peg out of the peg box. Rub a small amount of soap onto the peg where it rubs in the peg box holes, this will help the peg to turn smoothly.
2. Rub some pencil into the string grooves on the nut and on the grooves in the bridge.
3. Insert the ball end of the new string into the slot on the tailpiece of your violin.
4. With the soaped peg fitted back into the peg box thread the new string into the hole in the peg and turn the peg away from you. **STEP 1. Diagram A**
5. Aim to overlap the end of the string on the second turn of the peg. Guide the winding towards the inside wall of the peg box, this will pull the peg inwards and prevent it from slipping back when tuning. Tighten the string to keep the bridge in place and tune to pitch. **STEPS 2,3 & 4 Diagram A**
6. After the G- string move onto the E- string and repeat the process. By changing the two outer strings first you will maintain even pressure on the bridge to prevent it slipping. Next repeat the process for the D & A string.



Changing Strings

Step 1.
Push the tip of the string through the peg hole until a short length protrudes on the other side.

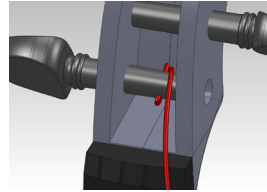
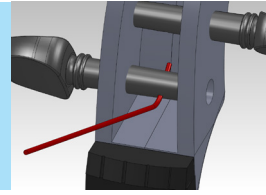

Step 2.
Turn the peg away from you using your finger to direct the first coil onto the outer side of the peg box.

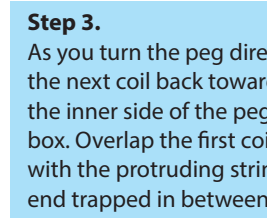

Step 3.
As you turn the peg direct the next coil back towards the inner side of the peg box. Overlap the first coil with the protruding string end trapped in between.

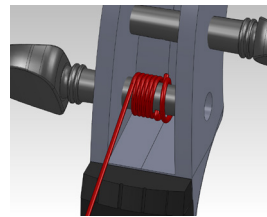
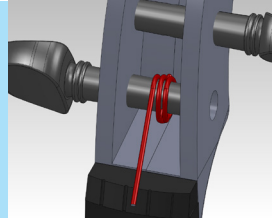

Step 4.
Keep turning the peg and directing the coils towards the wall of the peg box.

Repeat the process for all four strings.

(Dia A) Check the position of the bridge using (Dia D) in this guide

For more information visit www.stentor-music.com



Copyright 2019.

Stentor Music Co Ltd, Albert Road North, Reigate, RH2 9EZ, UK

Stentor

The Stentor name is known for quality, consistency and reliability. Stentor violins, violas, cellos and basses take students from their very first instrument up to professional level. Teachers and music educators everywhere recognize the quality and value we offer.

Violin and Viola care guide

Thank you for purchasing a Stentor instrument. We wish you success and enjoyment with your string playing. This short guide contains some useful information about your instrument and how to care for it. If you are unsure about any of the topics in this guide please contact your retailer or local music shop for further advice.

www.stentor-music.com



Storage and humidity

Avoid leaving your instrument in excessively hot or cold places. For example in your car over night or next to a radiator. Problems arise from sudden changes in temperature which can cause cracks. The wood in your instrument will adjust to the humidity conditions in the air around it. It is a good idea to keep your instrument in its case when not in use.

Diagram B shows some of the many different parts of your instrument.

ITEM	DESCRIPTION
1	Fingerboard
2	Neck heel
3	Tuning Pegs
4	Front
5	Bass bar
6	Bridge
7	Tailpiece
8	Top block
9	Ribs, blocks and linings
10	Back
11	F-holes
12	Sound post
13	Endpin

(Dia. B)

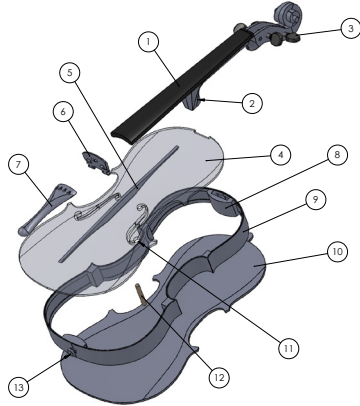

Cleaning



Keeping your violin clean will help to preserve it. Each time you play white dust from the bow rosin can build up, this can eventually become hard and stick to the front of your instrument. Wipe away the dust with a soft cloth after you have played. It is generally best to avoid using liquids to clean your instrument but there are some cleaning solutions on the market. Check instructions first.

Tensioning your bow.

(Diagram C. shows the parts of a bow.) Tension and de-tension your bow by turning the button on the screw (No 2). As you tighten the screw the stick (1) will bend and the hair (3) will become taut. Be careful not to over tension the bow, you should aim for about 10mm distance between the hair and the centre of the curved bow stick. Over time the hair of your bow will wear out and need to be replaced this can be done by a skilled technician. If you have a P&H bow you can re-hair it yourself using the patented re-hair system. Keep your bow in the case when not in use to protect it from accidental damage. Loosen the bow hair when not in use but not so much that the hair hangs loosely. Do not leave your bow fully tensioned inside your case.

ITEM	DESCRIPTION
1	Bow stick
2	Button and screw
3	Bow hair
4	Frog

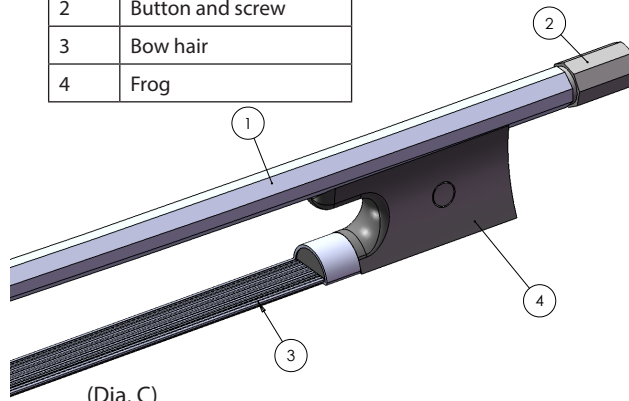

(Dia. C)

Rosin your bow

You will need to apply rosin to your bow before playing. Avoid handling the hair with your fingers to prevent grease and dirt being transferred. Tension your bow and carefully draw the hair across the block of rosin allowing powder to attach itself to the bow hair. The rosin powder increases the friction as the bow is drawn across the strings of your instrument. Rosins generally come in light and dark, light being soft and dark harder. Keep the rosin cool as it will melt in hot temperatures. Clean rosin dust from the stick of the bow with a dust cloth.

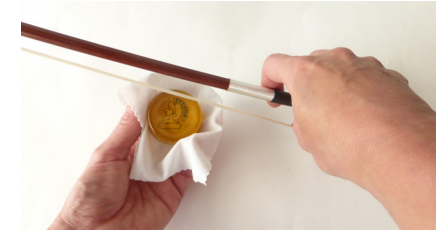

Check the position of the bridge

Diagram D; shows the correct position of the bridge from a side and top view. On the side imagine a centre line running through the horizontal plane of the instrument, the back/flat face of the bridge should be perpendicular (90 degrees) to this imaginary line. On the top view the bridge should sit equally between the nicks on the f-holes. When tensioning the strings the bridge will start to lean forward. You can move the bridge back into the correct position (Dia. D) by applying gentle & even pressure with your thumbs and fore fingers. Ensure the feet of the bridge are sitting flat on the front of the instrument. Be careful not to over tension strings particularly the E string as they will become stretched and break.

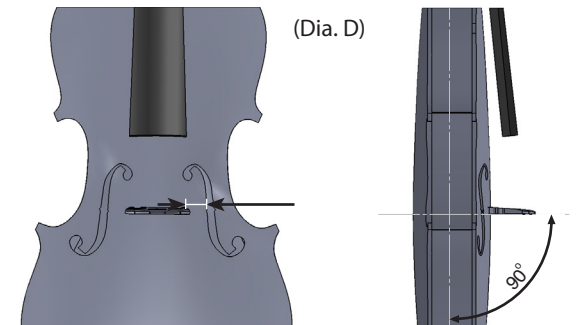

(Dia. D)